

CORE CHUCKING

RM 200.3 Increase productivity with shaftless core chucks!



RONCO
MACHINE & RIGGING

www.roncomachine.com | sales@roncomachine.com | 1.877.33.RONCO | St. Augustine, FL | Reading, PA | Lake Winola, PA | Albany, GA | Exeter, UK

TECHNICAL CHARACTERISTICS

Min/Max Parent Roll Width	30" - 110" (762mm to 2794 mm)
Min/Max Parent Roll Weight	Up to 3,500 lbs (1587Kg)
Min/Max Web Speed	2,500 ft/min (762 m/min)
Min/Max Parent Roll Diameter	45"-100" (1143mm-2540mm)
Core Sizes	3"-14" (76.2 mm to 355 mm)

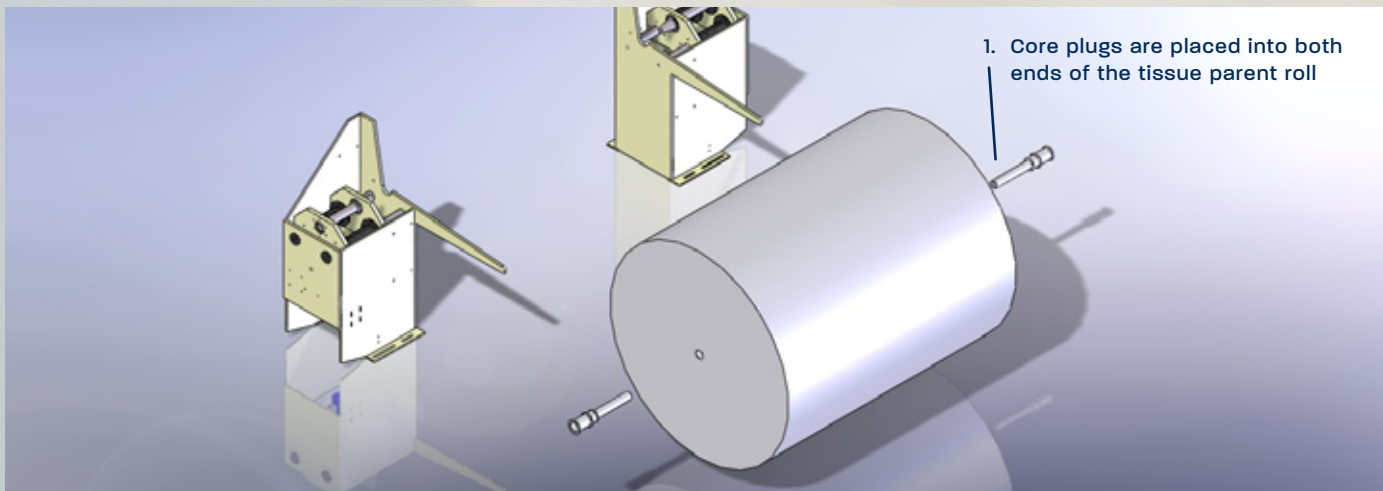

1. Core plugs are placed into both ends of the tissue parent roll

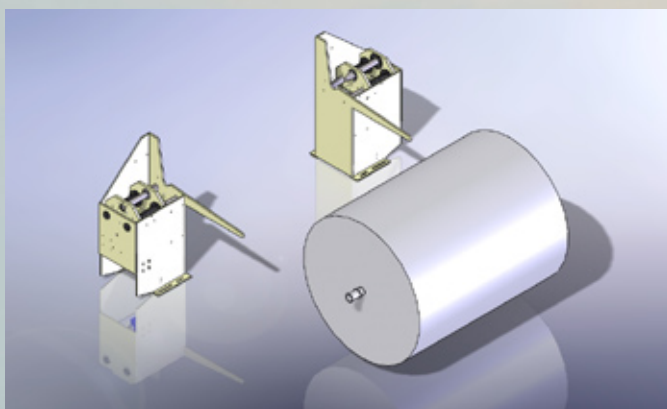

2. Once parent roll is loaded, it is locked with core chuck cylinders

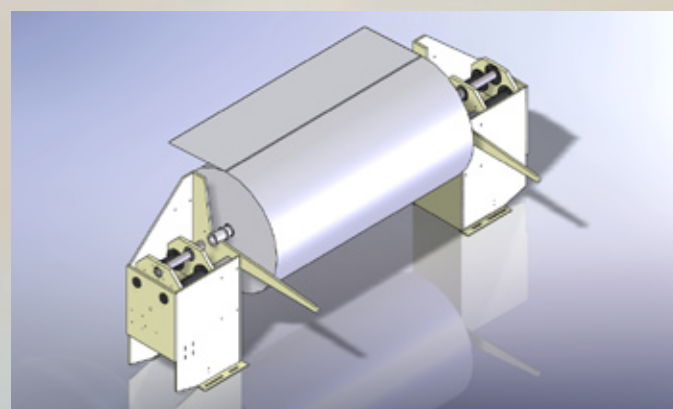

3. Loaded parent roll - Tissue is threaded through the embosser